



SPUR LINE

Volume 45, Issue 3

September 2011

© Copyright 2011 Arizona Division, PSR, NMRA

NMRA CONVENTION—SACRAMENTO 2011



In This Issue:

Table of Contents.....	2
Fall Meet Agenda.....	3
Superintendent’s Corner.....	4
Direct from the Director.....	5
From the Nominations Chairman.....	6
PSR 2011 Convention / Flagstaff.....	7
Chief Clerk & Paymaster Report.....	9
Achievement Program.....	10
Lenny’s Luck.....	11
From the Editor.....	11
A Little Bit of History.....	12
Track Bus Wiring.....	14
The Black Canyon Railroad.....	17
Coming Events.....	21
Railettes	22
Arizona Division Roster.....	23
Arizona Clubs.....	24
Hobby Shops.....	27
Tucson Meet Map.....	29

**** WANTED ****
GOOD QUALITY MODEL KITS, TOOLS, RR EQUIPMENT, ETC. FOR DOOR PRIZES
AT UPCOMING

FALL MEET - ARIZONA DIVISION, PSR, NMRA

Saturday, November 12, 2011 - Tucson, Arizona

DEPOT **Junior League of Tucson**
2099 E. River Road, Tucson, AZ (*Locator map on last page*)
Meet Contact: Alan Vincent (623) 249-7553

REGISTRATION \$7.00 - Coffee Provided; FREE - If you join the NMRA at Registration.
 \$3.00 - If NMRA member under 21 years of age.
 (*Bring your membership card.*)

SCHEDULE

9:00 am - Registration opens. Enter contests until noon.
 10:00 am - CLINIC: Don Stewart—Planting Buildings / Scenery
 11:00 am - Business Meeting and door prize drawings
 11:45 am - Break for lunch at a restaurant of your choice
 1:00 pm - CLINIC: Wayne Wesolowski—Urethane Casting—a modeling addiction
 2:00 pm - CLINIC: Richard Dick—Laser Cutting for Structures
 3:00 pm - Announce contest winners, door prize drawings.
 3:45 pm - Layout Tours – Flyers available at the meet

CONTESTS

A complete line up of NMRA contests is planned. We are including Levity, Favorite Train and the ever popular photo contest. The Favorite Train subject will be “Your Favorite Train”,. Levity will be “Grab Bag”. Trains are a maximum of ten cars. Bring your favorite model for the popular vote Favorite model contest and share it with other attendees. You must be a member of the NMRA to enter contests.

Give our contests a try. You may win an award!

SWAP MEET:

Tables will be available at 8:30 AM after the sellers' registration is paid. There is no fee for tables, but only Arizona Division members are allowed to sell. Anybody can buy! Please only one table per seller until everybody has a table.

**Please note all swap meet sellers must be NMRA members and must register.*

RAILETTES: A fun & exciting project activity is planned for the ladies. We promise that you are going to laugh and have a good time making it. Come join in on the fun!



SUPERINTENDENT'S CORNER

BY: ART CARLTON



Happy railroading . . .



DIRECT FROM THE DIRECTOR*BY: RICK WATSON*

As I reach the end of my second term as Arizona Division Director, I realize that this is my last column for the Spur Line. During my tenure, I've had the opportunity to work with a great team on the PSR Board of Directors and serve our Division. I truly appreciate the opportunity I have had.

I would like to officially congratulate the winner of the election for Division Director: Dave Irick. I know Dave will be an excellent leader and will ensure our division's continued success. I look forward to working with Dave during the transition. I will provide him all the support I can while we transition and beyond. I would also like to congratulate the winners for Superintendent: Alan Vincent and Chief Clerk and Paymaster: Jim Tuck. I'm convinced that as we transition leadership in the Arizona Division, we have a great team that will ensure continued success.

The annual PSR Convention is coming up quickly. Larry Gibbs is Chairman. He and team have been working hard to develop a great program. I'm very confident that all who attend will have a great time up in the cool high country of Arizona.

As I reflect back over the last four years I've served as director, I have a number of Arizona Division members I would like to thank. First are Superintendent Art Carlton and Chief Clerk & Paymaster Richard Dick. We have worked as a team to improve our division. I would like to thank Contest Chairs: Duane Buck, Kevin Looff, and Dave Irick for their work. Also, Alan Barnes who has always been there to help make the contest room a success. Thanks to Spur Line Editor Frank Baker for stepping up and taking the Spur Line to the next level. Thanks to Lee Stoermer for stepping up to take over the website (we are still in transition). Thanks to Membership Chair Gordon Geiger for filling a long time empty position. And to our AP Chair Don Stewart for his coaching and help. And I cannot forget to recognize Janet Spooner. She is the driver behind our Railette programs and is such a wonderful person.

When I originally ran for director, I noted that change is a constant and wanting to be a change agent. I have driven change for the division and accomplished more than I set out to do. I am proud of that.

I will now refocus myself on working toward my Master Model Railroader. And maybe get that done...for a change!

FROM THE NOMINATIONS CHAIRMAN

BY: LENNY SMITH

I would like to thank everyone in our division who through their name in the hat for Superintendent; David Jerry and Alan Vincent: for Chief Clerk & Paymaster; Doc Shafer & Jim Tuck... All candidates are well respected in the model RR community which was reflected in the voting. The first week of elections the lead for the winning candidates changed daily showing interest and support for all candidates. We had 79 members participate in the voting , an increase of four more voters than our last election. Congratulations to the WINNERS.



DIVISION DIRECTOR
DAVID IRICK



DIVISION SUPERINTENDENT
ALAN VINCENT



CHIEF CLERK & PAYMASTER
JIM TUCK



Pacific Southwest Region's 2011 Convention "Rails to Rims" Flagstaff, Arizona 2011

This year's event is being hosted by the Arizona Division (www.azdiv-nmra.org) from Wednesday, September 21st through Sunday, September 25th, 2011. The venue is the Radisson Woodlands Hotel on historic Route 66 in Flagstaff. The Convention Com-

mittee has planned a variety of activities that will be interesting, informative, and unique. There will be over 30 prototype and model railroad oriented clinics, many operating sessions, and prototype tours. The keynote tour is the Grand Canyon Railway shop facilities in Williams with a visit to the Fray Marcos (site of the proposed Arizona State Railroad Museum) and NRHS rolling stock at the shop. Tour arrangements are being finalized for rail operations at the Camp Navajo Army Depot, SCA Tissue paper mill, and the Ralston-Purina pet food plant. The "Haunted Flagstaff" and "Theme Town" tours will also be highlights. Northern Arizona is home to many spectacular rail-fanning locations. A field trip to the Johnson Canyon Tunnel and Steel Dam historic locations is a planned and detailed guides to other areas of interest will be provided. The Flagstaff area is home to several unique layouts that will be available for tours including a compressed version of the Grand Canyon Railway from Williams to the Grand Canyon! The Flagstaff Model Railroad Club, home of the Mountain Pacific Lines (a bridge line connecting Phoenix and Provo Utah) will be hosting operating sessions through the Convention. The Convention schedule will be full including the NMRA Contest, the annual Awards Banquet, Auction Night, Swap Meet, and the annual PSR membership meeting. Janet Spooner, our Railette Chair, has again planned a busy and interesting time for the ladies. Many opportunities for fun and unique non-rail family activities are available in the Flagstaff/Northern Arizona area and details will be provided at the Convention.

As you can see, we have a lot of great activities planned for this year's event. We have planned with the goal of providing you with the best of what the railroad "rich" town of Flagstaff has to offer. (continues on next page)

Thank you to the many Division members that have registered!

If you haven't and your schedule allows - get on board and register today - you'll miss a great time if you don't! Also, our Convention Hotel is filling up and the weekend is also Northern Arizona University's Parents Weekend, so timely reservations are advised.



If you haven't and your schedule allows - get on board and register today – you'll miss a great time if you don't! Also, our Convention Hotel is filling up and the weekend is also Northern Arizona University's Parents Weekend, so timely reservations are advised.

The 2011 PSR Regional Convention is Coming to Flagstaff!!!

***What:* PSR 2011 Regional Convention**

***When:* September 21 – 25, 2011**

***Where:* Flagstaff – Radisson Hotel?**

What can you do? Help make it a huge success!

Need volunteers for planning, clinics, contests, etc.

Contact: Larry Gibbs, Flagstaff Model RR Club

Flagmrrc@gmail.com or (928)699-3449



An Affair with Trains

301 W Deer Valley Road, Suite 4

Phoenix, AZ 85027

Phone: (623) 434-6778

www.aawtrains.com



CHIEF CLERK & PAYMASTER REPORT

BY: RICHARD DICK



Arizona Division has had no Division Meets since our last report; but the Division did send out a Rail joiner to all members for election of Superintendent and Chief Clerk/Paymaster. That cost is reflected below.

There have been increased sales recently of some of the railroad cars from previous Regional Conventions held in Arizona. And I have a request for four more from one member. We have good prices on some very nice cars; stop and see what we have!! There are also various pins and patches from previous conventions. I will have these at the Regional Convention in Flagstaff and at the next Division Meet in Tucson.

Account Balance, March 31 , 2011	\$6,510.16
----------------------------------	------------

Revenue:

Total Revenue	\$0.00
---------------	--------

Expenses:

Spur Line: June 2011:

ImageWorx - News letter	\$667.18	\$667.18
-------------------------	----------	----------

Other Expenses:

Bank Fees	\$33.04	\$33.04
-----------	---------	---------

Total Expense	\$700.22
---------------	----------

<u>Income</u>	-\$700.22
----------------------	------------------

Account Balance, July 31, 2011	\$5,809.94
--------------------------------	------------

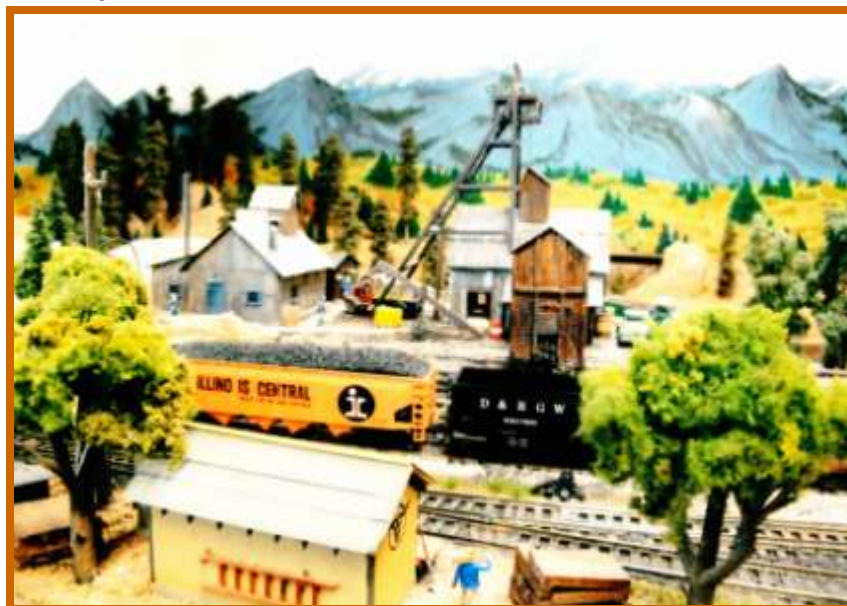



ACHIEVEMENT PROGRAM

BY: DON STEWART

Statements of Qualifications continue to roll in from the Arizona Division.

Gordon Geiger earned his Master Builder – Scenery Statement of Qualifications (SoQ) (PSR Certificate #304). It will be presented at the Regional Convention in Flagstaff.

Rick Watson earned his Certificate for Association Official. His PSR Certificate number is #305. It will also be presented at the Flagstaff Convention.

Bob Libbey submitted two Statements of Qualification for Model Railroad Engineer – Electrical (PSR Certificate #309) and Chief Dispatcher (PSR Certificate #310). These made it into National for approval in time to be presented at the PSR Convention in September.

Without a summer meeting there are no other Merit Awards from contests, but several were generated by Richard Petrina (HAS Mine, Slim Pickens Produce, Wood Trestle, Roundhouse, Romig Manufacturing) These will also be presented at the PSR Convention.

Congratulations to these modelers for their excellent work!

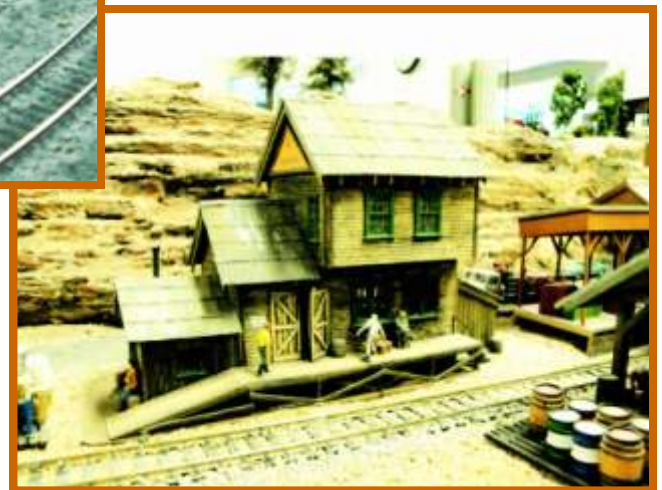

Photo's from Richard Petrina's Merit Award submission

**FOR MORE INFORMATION ON THE ACHIEVEMENT PROGRAM
CHECK THE NMRA WEBSITE AT: WWW.NMRA.ORG/ACHIEVEMENT**

LENNY'S LUCK!

Something's just work out right. A recent business trip happened to coincide with the NMRA Convention in Sacramento. After completing my work, I went over to the NMRA convention to see some old friends, find some new toys and check out new stuff. I had a blast at the NMRA National Convention thanks to a little old lady. I took AMTRAK up to Sacramento and was flying back the evening of July 8. On July 7, I was cashing in on all the great bargains I got at the silent auction. I left the convention center downtown main street in Sacramento and when I got to my rental car, noticed my wallet was missing. I broke out in a sweat. I retraced my steps and no luck. Now I have no ID and can not fly home without any ID.

Then my cell rings, it is Mary Ann, my wife calling from Casa Grande. Some nice little old lady had found my wallet, went through it and found my University of Phoenix staff card. She called the University of Phoenix and as fate would have it, the person who answered the phone knew me and called Mary Ann. Mary Ann immediately called me and gave me the ladies cell number and within a half hour i had my wallet back all in tact.

She said "there are good people in Sacramento".....I had to push this good Samaritan to take a rewardTHANK YOU AGAIN.

Lenny

EDITOR'S UPDATE

BY: FRANK BAKER

A special thank you to Alan Barnes for sending me an article on track cleaning. The article was in the August issue of Model Railroad Hobbyist and presents another viewpoint of track cleaning.

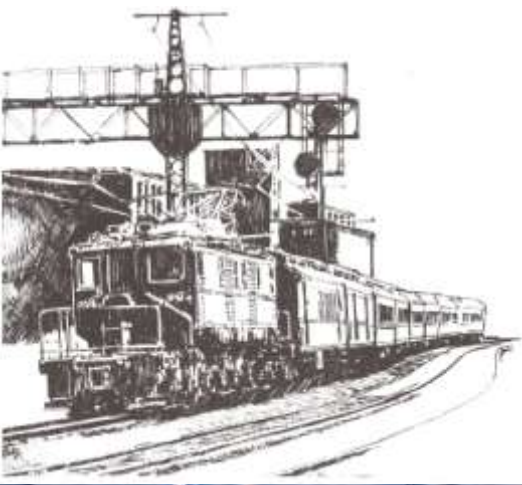

ment of Model Railroading in Arizona.

In this issue we pay tribute to Harold Shelton and his beautiful Black Canyon Railroad. Harold has been an inspiration to many modelers here in the valley. Always the consummate gentleman, Harold has shared many years of his personal experience with everyone he meets. Harold is moving to Wickensburg to be near his family and has found a home for his railroad at ***An Affair With Trains***. Bob and Alan at ***An Affair with Trains*** are looking for volunteers to reassemble Harold's creation.

Arliss Powell, former editor of the Spur Line has graciously consented to provide us with some history on the Arizona chapter of the NMRA. Her photographs of people and layouts should give everyone a better understanding of the develop-

Continuing with our focus on track cleaning, switch machine mounting, Rick Watson has written a very thorough article on DCC wiring that I think you will find very timely and critical for excellent train operation.

A LITTLE BIT OF HISTORY

BY ARLISS POWELL

It is often said that Rome wasn't built in a day. Nor was the Arizona Division, NMRA. Today's members enjoy the initiative of early modelers as well as those who followed. Natural changes and improvements have occurred along the way--always because a member who was a leader saw an opportunity to fill a need, a way to improve the division. Pictures of some of these people recently came to our attention and we'd like to share them with you.

LEROY THOMPSON, MMR - Leroy was one of the very first people to earn the Master Model Railroad designation. He told of taking his wife, Dorothy, with him when he was working on his locomotive. He knew how tall she was, so he had her stand by the various sections of the locomotive and took pictures to get the measurements. He took modelers under his wing, giving them help in becoming not only better modelers but stressing working together for the common good of the hobby and its various organizations and groups.



"HUBE" HUBENTHAL - another early NMRA personage. He and his wife retired to the Sun City area. He immediately became active in the Arizona Division. "Hube" had great patience with modelers who grumbled about rules and why you had to do this or that. The "big picture" of the model railroading hobby was important to him.

Picture - taken October 5, 1992 Presentation of the 50 Year NMRA plaque with then Superintendent. Roger von Seeburg



A LITTLE BIT OF HISTORY

BY ARLISS POWELL

(CONTINUED)

ED RAVENSCROFT - Another MMR with a single digit number. He too was instrumental in the early formation of NMRA. His layout in the Phoenix area was basically set up for switching. It became a monthly mecca for several local modelers who enjoyed spending an evening working out the switching problems Ed prepared. (Sorry, no picture)

TOM DRAPER - Tom represented the division on the national level, serving as Treasurer of NMRA for many years. This, of course, included involvement in the National Conventions. You'll still see him at Division meets and Swap Meets in the Phoenix area.

We plan to continue to bring you more people pictures, layouts and tales of people from the past. If you have a story that you would like to share, please contact the Spur Line Editor.



TRACK BUS WIRING

BY RICK WATSON

In 2009 I built my railroad. I'm proud of the fact that I went from concept to first operating session in 11 months. That took a lot of planning and execution. Because my layout is designed exclusively for operations, reliability was and is extremely important. No just electrically, but track work, rolling stock, and motive power as well. To date, I've hosted 44 operating sessions and have not had any electrical related issues.

The premise of this article is wiring, but I'd like to identify some key decisions in support of that. First of all, DCC was a must. My preference is NCE, but it is *my* preference. Next, I wanted to ensure an operator on one side of the railroad would not short out the entire railroad. So, I divided the railroad into 5 power districts. Each power district has its own dedicated circuit breaker. All breakers and the NCE system are mounted on wall mounted panel under the layout. The panel IS removable if heavy maintenance is required. A single power strip is plugged into the wall allowing a single button to turn the railroad on/off. See figure 1.

Another preference of mine is that **each and every piece of track has feeders**. I prefer to eliminate any dependence on rail joiners for electrical power. To that end, I do not solder rail joiners for electrical purposes, but rather add feeders to each piece of track. Even to 1" sections of track. That may be over engineering, but is *my* preference.

Color codes: I decided to stick to a color code system to try to make my life easier.

- Track Bus: blue and white 12 gauge stranded wire
- Track Feeders: white or red and blue or green 22 gauge solid wire
- Feeder placement: white or red – rail closest to the aisle, blue or green – rail farthest

Why did I mix feeder colors? Because the free wire I got had 4 wires in the bundle!

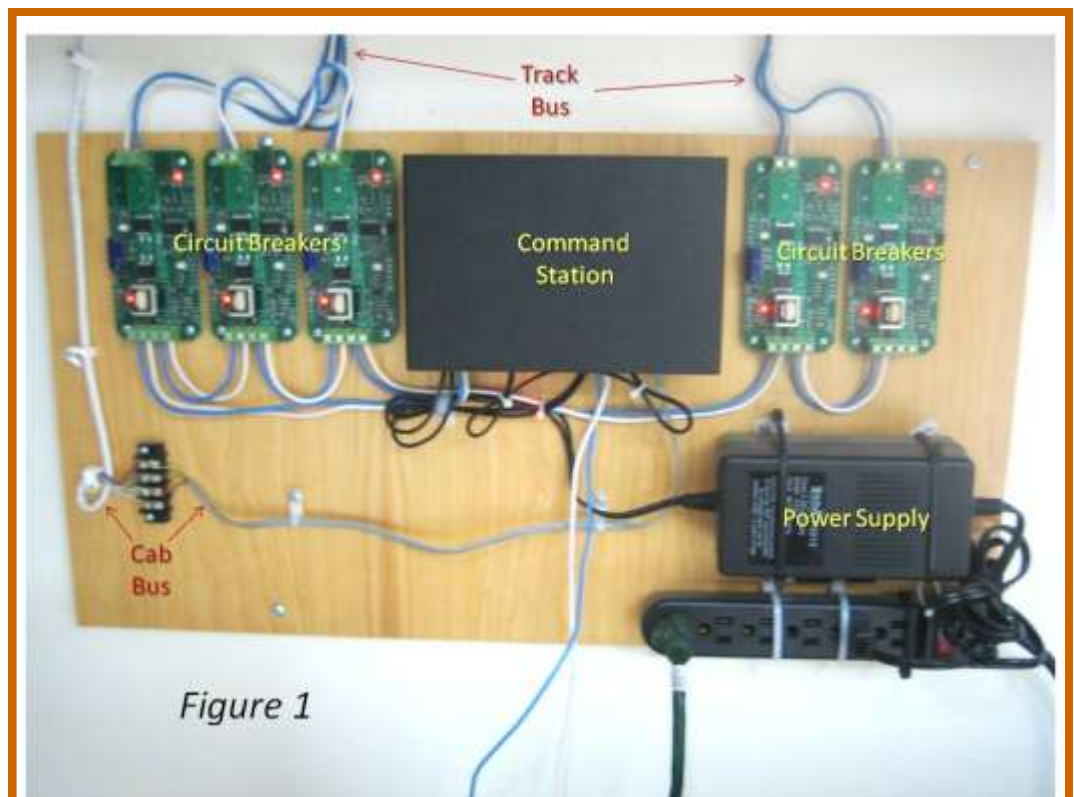
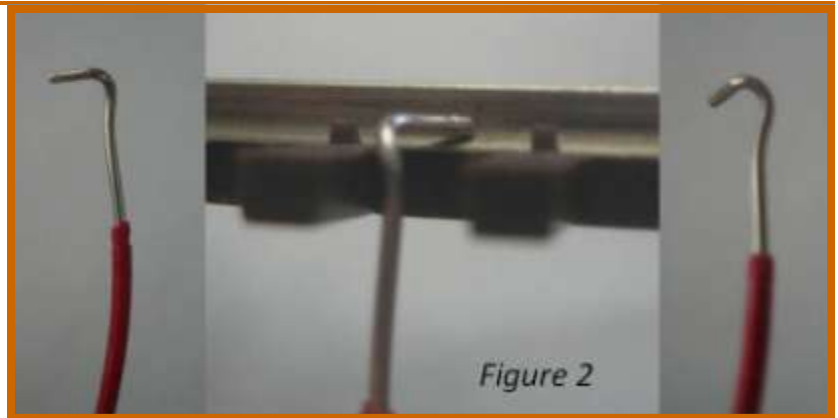

Figure 1

All feeders are soldered to the web of the rail for the rail connection. I bend the wire to fit inside the web. See figure 2. Because I keep the feeder lengths short, I can use a smaller gauge wire. In almost all cases, feeder wire length is 8 inches or less.



As to the actual bus to feeder connection, I use a sub bus. See figure 3. The sub bus then connects to the track bus.

I found this to be an easy way to bridge bus to feeder connections eliminating the need to bundle multiple feeders to on bus connection. Maintenance is much easier as well.

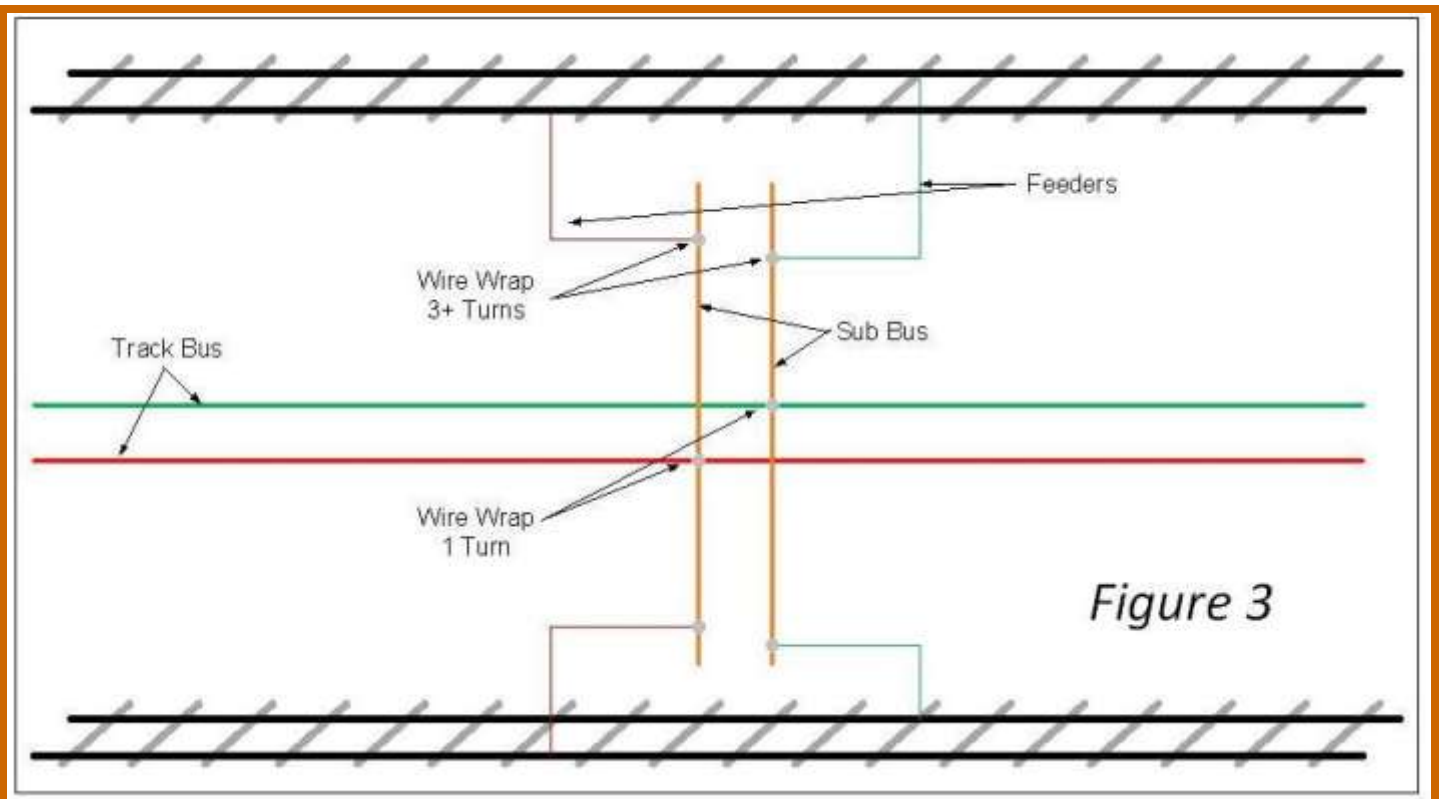

I used 14 gauge solid copper wire for the sub bus. I had a bunch of scrap 14/3 Romex (household wire) that I used to supply the copper wire. I stripped a lot of it and would try to find a roll of un-sheathed wire if doing it again. I stripped way too much wire!

The process:

I first solder all of my feeders to the track dropping them through the bench work. Once the feeders for a section are complete, I align them under the layout to get an idea of where the sub bus should be routed. In many cases, the sub bus can be bent to allow more feeders to be connected. I cut a piece of sub bus (14g solid copper) a 3-4 inches longer than needed. I prefer to leave some extra on each end. I begin attaching the feeders (usually the rail closest to the aisle). Most are trimmed to be 4-6 inches under the bench top. Each wire is stripped and wrapped (Western Union wrap) around

the sub bus. See figure 4. Each feeder wire is then soldered to the sub bus. I then repeat the process for the other rail feeders.

Once all feeders are connected to each sub bus, I connect them to the track bus. This is done by stripping a 1" section of the sheathing off exposing the stranded 12g copper wire. See figure 5. I then wrap the exposed section around the sub bus wire and solder. I repeat it for the other bus.

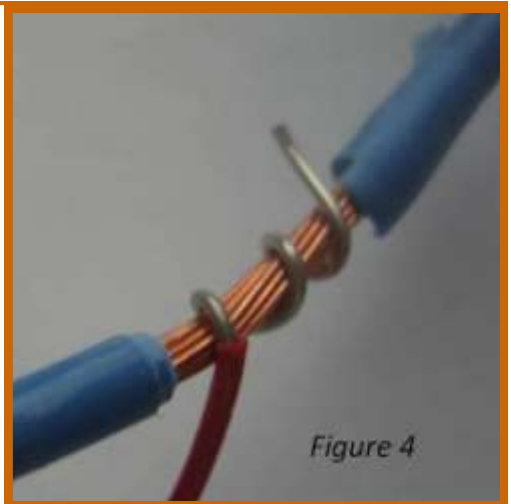

Figure 4



Figure 5

Each sub bus is arranged so it cannot contact/short the other.

Each connection to the track bus is offset by a few inches to ensure no shorting. I do not cover the wire connections as they have been soldered. If your preference is to cover them, then heat shrink or liquid electrical tape is recommended.

See figures 6 and 7 for bus connections.

A couple of notes on the track bus wire. I prefer to buy stranded wire from an automotive lighting supply house. I use the Lighthouse in Phoenix. The reason I use automotive wire is that the case/sheath is soft and flexible. This makes inline stripping of the wire much easier. See figure 6. This is in contrast to the wire available at Home Depot or Lowes which has a hard plastic sheath. I use a stripping tool that you squeeze and it strips the sheath away (see picture).

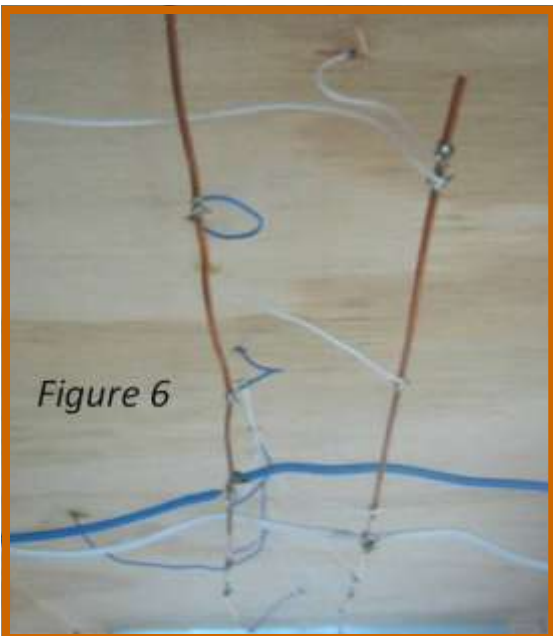

Figure 6

That's about it. I have found this to be very simple and effective. The only downside is that my arms got really tired soldering all the feeders to the sub bus as it was over my head when sitting under the layout soldering.

Please feel free to contact me with any questions you may have. My email is rwtempe2@gmail.com

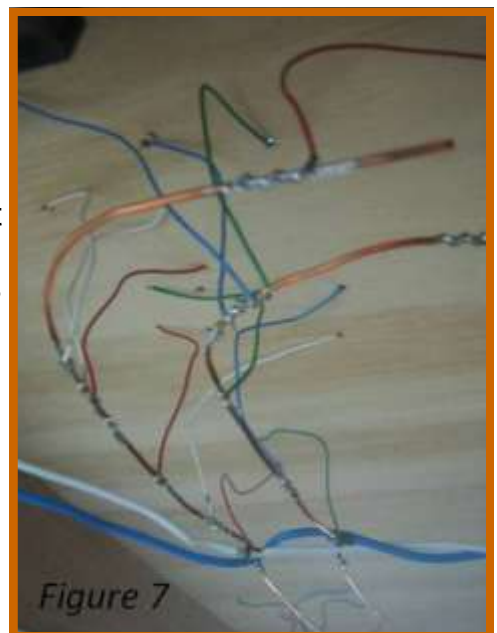

Figure 7

THE BLACK CANYON RAILROAD

BY FRANK BAKER

The year was 1975. After almost seven years in the planning, construction began on The Black Canyon Railroad. Harold Shelton, owner of the railroad, began his project that would span almost four generations. Over that timeframe, Harold designed and built a wonderful HO layout that he shared with many in this hobby and community.

In 2000, Harold formed an operating club for his railroad. Members of his club included: Gary Carter, Robert Hedges, Richard Petrina, Eric Hiser, Dave Thurman, Ben Vernille, Alan Elsroad, George Stevens and Dennis Surufka and Harold—The Gang of Ten. What a wonderful time they must have had in the back room of Harold's house.

Someone once said that a picture is worth a thousand words. You will see in the following pictorial that Harold is indeed a master modelbuilder. His understanding of form, color and texture are embedded in his layout creation. From ties begun on his table saw in the garage to the exquisitely built structures, lighting, wiring, signaling, scenery and structures, he has created a work of art consisting of countless hours of TLC.



THE BLACK CANYON RAILROAD

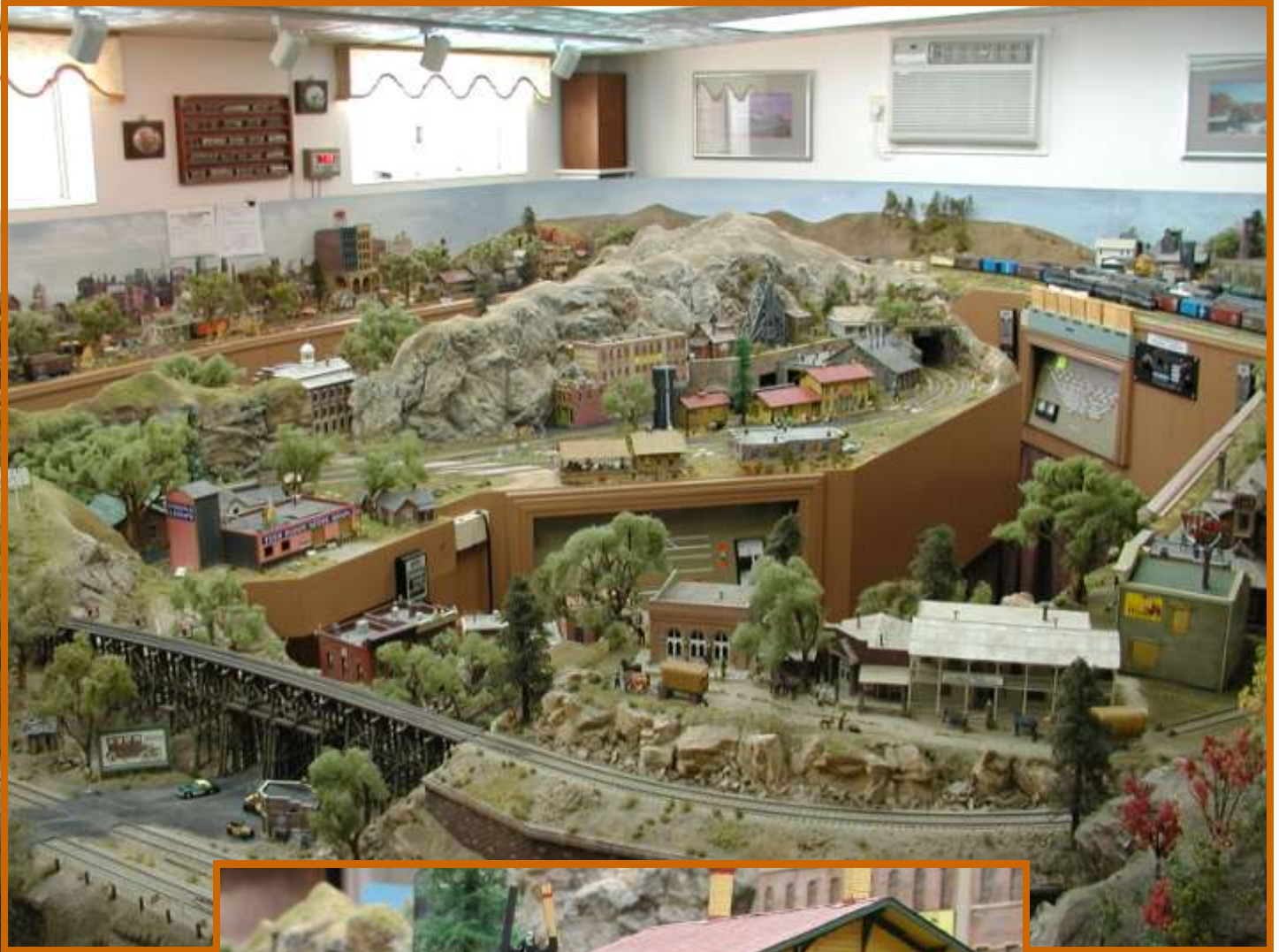

THE BLACK CANYON RAILROAD



THE BLACK CANYON RAILROAD



As time has marched on, Harold and his wife have decided to retire in Wickenburg. Harold was very concerned about his creation and sought out someone that would take care of his passion for model trains. Bob Kocher and Harold had conversations and an agreement was reached.

Last month, the railroad began its journey to its new home in North Phoenix. The layout has been dismantled and removed from Harold house and transported to An Affair with Trains where it will be set up at the back of the building for everyone to enjoy.

Bob Kocher and Alan Vincent are looking for volunteers to help put Harold's layout back to its original form. Please contact them at An Affair With Trains @ (623) 434-6778

On behalf of everyone in the NMRA, we would like to thank Harold for his time, effort and sharing of his beautiful railroad. We look forward to enjoying his creation for years to come.

COMING EVENTS

- September 21-25, 2011** PSR Regional Convention / Flagstaff, Az.
- October 8-9, 2011** Scottsdale Annual Rail Fair / Scottsdale
McCormick– Stillman RR Park (10AM to 5PM)
Admission is FREE
- October 15, 2011** Adobe Mountain Railroad Park Swap Meet / Phoenix
23280 N. 43rd. Ave.
Admission is
- November 5, 2011** Fall Train Show / Tucson
Las Cazuelitas Event Center—behind Grant Inn
Admission \$5.00
- November 12, 2011** Az. Div. Fall Meet / Tucson
- January 21, 2012** Winter Train Show / Tucson
- March 2012** Az. Div. Spring Meet / Sun City
Fairway Recreation Center, 107th ave. & Peoria ave.



RAILETTES**BY: JANET SPOONER**

Hi Ladies,

.Well, we are getting close to another PSR Convention. This time in cool and gorgeous Flagstaff, AZ. Once again we have a great program planned for the ladies and I hope to see many of you in attendance. On Thursday morning at 9:00 a.m. to 10:00 a.m., we will be having a "Welcome" for the ladies with coffee, pastries or doughnuts, and goodies for those who stop by. Hopefully you will take some time to stop by and get to know us. You might even find something that we will be doing that you might be interested in and want stay. We have some very talented ladies giving up their time and talent to entertain, educate or show you how to make something. First of all we have Kim Fowler showing us how to make a Santa napkin, mini-scrapbook, fabric flowers and how to hand quilt. Then Linda Irick will be showing us how to "Climb our Family Tree" and "Recycle, Reuse, and Save". The second talk will led to her to showing us how to turn those plastic bags into tote bags, that can be used in place of more plastic bags at the grocery store. I will be showing how to turn a piece of paper into a folded multi-purpose greeting card, invitation, or gift enclosure. We will also be making gifts that will be sent to a local shelter for battered and homeless women, but to do this I need you to bring those toiletries that you get from all those hotels and motels you have stayed at. The more we get the more gifts we can make. When we were in Las Vegas, we sent a local shelter over 70 gifts of washcloths and toiletries for use by the residents. Lets see if we can do better in Flagstaff. The Ladies luncheon on Thursday will be a delight, I'm sure. Then Thursday evening is the ever fun Chinese auction. Hopefully the guys will not forget us and include some items the ladies will want to put their tickets in the jar for. Saturday night is the banquet and awards evening and it is always fun and entertaining.

So ladies, that is what we have planned for your time in Flagstaff. Come by and have fun. Make things, learn things, laugh, make new friends, renew acquaintances, gossip, and have a great time in the Railette room, a happening place. Give us a chance, you might like it.

Janet Spooner, Railette Chair

Coronado  **SCALE MODELS**

1544 E Cypress St. Phoenix, AZ 85006

Phone: 602-254-9656 E-mail: coronadoscalemod@aol.com

Hours: Mon-Fri 8am-12pm & 1pm-5pm, Sat 8am-12pm

ARIZONA DIVISION ROSTER

Director - David Irick

5722 W. Cohise Dr. Glendale, AZ 85302 (623) 435-8534 email: Director@AzDiv-nmra.org

Superintendent - Alan Vincent

7001 W. Topeka Dr., Glendale, AZ 85308 (623) 249-7553 email: Superintendent@AzDiv-nmra.org

Chief Clerk & Paymaster - Jim Tuck

2829 North Fremont Blvd., Flagstaff, AZ 86001 (928) 773-9194 email: Paymaster@AzDiv-nmra.org

Membership Chairman - Gordon Geiger

5340 E. Placita Casa, Tucson, Az. 85718 (520) 529-6223 email: Memberchair@AzDiv-nmra.org

Contest Chairman - David Irick

email: ContestChair@AzDiv-nmra.org

Achievement Program Division Mgr - Don Stewart

2722 E. Bighorn Ave., Phoenix, AZ 85048-8984 (480) 759-5019 email: APChair@AzDiv-nmra.org

Nominations Chairman - Lenny Smith

1747 N. Gilbert Ave., Casa Grande, AZ 85222 (520) 836-7683 NomChair@AzDiv-nmra.org

Raillette Chair - Janet Spooner

10015 W. Royal Oak Rd. Apt 138, Sun City, AZ 85351 (623) 977-6760 RailletteChair@AzDiv-nmra.org

Spur Line Editor - Frank Baker

5319 E. Cortez Dr. Scottsdale, AZ 85254 (602) 672-6336 SpurLine@AzDiv-nmra.org

Webmaster - Lee Stoermer

3824 E. County 15 1/4 st., Yuma, Az. 85365 (928) 580-3209 email: Webmaster@AzDiv-nmra.org

Member Aid Chairman - George Lopez Cepero 915 East Monte Cristo Ave. Phoenix, AZ. 85022 (602) 993-2263 email: MemberAid@AzDiv-nmra.org

ARIZONA DIVISION WEBSITE: www.AzDiv-nmra.org



MY TRAIN SHOP MyTrainShop.com

1695 Mesquite Ave. #208A
Lake Havasu City, AZ 86403

Jerry L. Clark

P 928.505.4044

C 928.486.1975

F 928.855.0128

ARIZONA CLUBS**Flagstaff****Flagstaff Model Railroad Club**

Scales: HO, HOn3, and N

Contact: Larry Gibbs (928) 779-2282

On the web: <http://ucc.nau.edu/~twp/railclub>

Gilbert**Gilbert Model Railroad Club**

Scales: HO

Contact: Joe Padberg jpadberg@cox.net

On the web: www.gmrctrains.com

Goodyear**PebbleCreek Model Railroad Club**

Scales: HO and G

Contact: Bruce Petrarca (623) 935-4837

On the web: www.pcmrc.org

Phoenix**Arizona Model Railroading Society**

Scale: N, HO, and G

Contact: Steven David (623) 889-4613 steves-train@cox.net

On the web: www.azmodelrr.com

Black Canyon Model Railroad Club

Scale: HO

Contact: Harold Shelton (602) 242-0751

On the web: <http://www.bcrraz.net/>

Grand Canyon State Model Railroaders

Scale: HO modular

Contact: Bob Gibbs (480) 968-1760

On the web: www.GCSMR.org

Ponderosa North

Scales: Round Robin

Contact: Matt Furze mattfurze@cox.net

On the web: www.arizonarails.com/pncpage

Thunderbird Model Railroad Club

Scale: HO

Contact: Alan Vincent (623) 249-7553

On the web: www.trainweb.org/tbird

....continued on next page

ARIZONA CLUBS

Prescott

Central Arizona Model Railroad Club

Scales: Multiple

Contact: Steve Bumgardner (928) 775-3184

On the web: www.camrrc.com

Scottsdale

Scottsdale Model Railroad Club

Scales: HO and HOn3

Contact: SMRC01C@ScottsdaleModelRRClub.org

On the web: www.scottsdalemodelrrclub.org

Sun'N'Sand Model Railroad Club

Scale: N

Contact: Mark Vanacore (602) 410-1110

On the web: www.sun-n-sand.org

Sun City

Sun City Model Railroad Club

Scale: HO

Contact: Bob Batt (623) 734-6377

On the web: <http://hometown.aol.com/newriverwestern/NRNW.htm>

Sun City West

Sun City West Model Railroad Club

Scales: HO and N

Contact: Bob Butler (623) 556-5179

On the web: <http://www.scwclubs.com/> then select Model Railroad

Sun Lakes

Short Line Model Railroad Club

Scales: Open to all scales

Contact: Dave Olson (480) 895-7411

Tucson

Arizona & Southwest Model Railroad Society / Tucson NTRAK

Scale: N

Contact: John Scott (520) 250-2800

On the web: <http://home.comcast.net/~tucsonntrak>

....continued on next page

ARIZONA CLUBS

Tucson

Rincon West Garden Railroad Club

Scale: G

Contact: John Lawrence johnlaw1931@hotmail.com

Southern Arizona Society of Model Engineers (SASME)

Scales: HO and HOn3

Contact: Richard Dick (520) 790-5356

On the web: www.sasme.org

Yuma

Yuma Model Railroaders

Scales: Multiple

Contact: Lee Stoermer (928) 344-9417

On the web: www.yumamodelrailroaders.org

To have your club added to the list, please email your club info to SpurLine@AzDiv-NMRA.org



Litchfield
STATION
"Making DCC Fun!"

www.Mr-DCC.com

Jack Baer
Jack@LitchfieldStation.com

623-298-7355
1412 N. Central Ave., Ste. D
Avondale, AZ 85323-1316

ROY'S TRAIN WORLD
Exclusively Model Trains
Since 1974



1033 S. Country Club Dr.
Mesa, Arizona 85210
Hours:
Mon., Tue., Wed., & Fri. 9am to 5:30pm
... Thurs. 'till 8pm, Sat 9am to 5 pm
Closed Sunday

Phone: 480-833-4353
Fax: 480-833-9386
E-mail: trains@roystrainworld.com
Website: www.roystrainworld.com

ARIZONA HOBBY SHOPS

- THE HOBBY PLACE @ACE** 6959 E. 22nd St. Tucson, Az. 85710
(520) 747-9473
Email: thehobbyplace@gmail.com.
- AN AFFAIR WITH TRAINS** 301 West Deer Valley Rd., Suite 4, Phoenix, Az. 85
(623) 434-6778
Hours: Closed Monday,
Tues. – Fri 10:00 – 5:30
Sat. 9 – 5; Sun. 1 – 4
Email:
- CORONADO SCALE MODELS** 1544 E. Cypress St. Phoenix, Az. 85006
(602) 254-9656
Hours: Mon. – Fri. 8:00 – 12:00 / 1:00 – 5:00
Sat. 8:00 – 12:00
Email: coronadoscalemod@aol.com
- ROY'S TRAIN WORLD** 1033 S. Country Club Drive, Mesa, Az. 85210
(480) 833-4353
Hours: Mon., Tues., Wed., & Fri. 9:00 to 5:30
Thurs., 9:00 to 8:00, Sat., 9:00 to 5:00
Email: trains@roystrainworld.com
- HOBBY DEPOT** 216 w. Southern Ave, Tempe, Az. 85282
(480) 968-1880
Mon., Tues., Thurs 10:00 to 6:00 Wed., 10:00 to 8:00
Fri. 10:00 to 7:00 Sat. 9:00 to 5:00 Sun noon to 5:00
- HOBBY BENCH** 8058 North 19th Ave., Phoenix, Az. 85021
(602) 995-1755
Hours: Mon thru Fri: 9:30 to 8:00
Sat., 9:30 to 6:00 Sun., 11:00 to 5:00

ARIZONA HOBBY SHOPS

- ARIZONA TRAIN DEPOT** 755 E. McKellips Rd. Suite 5, Mesa, Az. 85203.
(480) 833-9486
Hours: Mon thru Sat. 9:00 to 6:00; 9:00 to 9:00 on Wed.
www.arizonatraindepot.com
- MY TRAIN SHOP** 1695 Mesquite Ave., #208A, Lake Havasu City, Az. 86403
(928) 505-4044
Hours: Mon thru Sat. 10:00 to 4:00; 9:00 to 12:00 on Sat..
- LITCHFIELD STATION** 1412 North Central Ave., Suite D, Avondale, AZ. 85323
(623) 298-7355
Hours: Mon thru Fri. 10:00 to 5:00
- BURLING'S TON OF TRAINS** 16939 East Colony Drive, Suite 2 Fountain Hills Az.
(480) 816-6501
Hours: Mon thru Fri: 11:00 to 5:00
Email: tonsoftrains@cox.net





SPUR LINE

Official Publication of the
Arizona Division, PSR, NMRA
FRANK BAKER, Editor

SATURDAY, NOVEMBER 12, TUCSON, ARIZONA

Depot: Junior League of Tucson, 2099 E. River Road, Tucson, AZ

Directions: From Phoenix go south on I-10 to the Ina exit. Go east to N. Oracle Rd. Turn south on Oracle Rd. and then east on River Road. The address is 2099 E. River Road.

Please park in the rear.

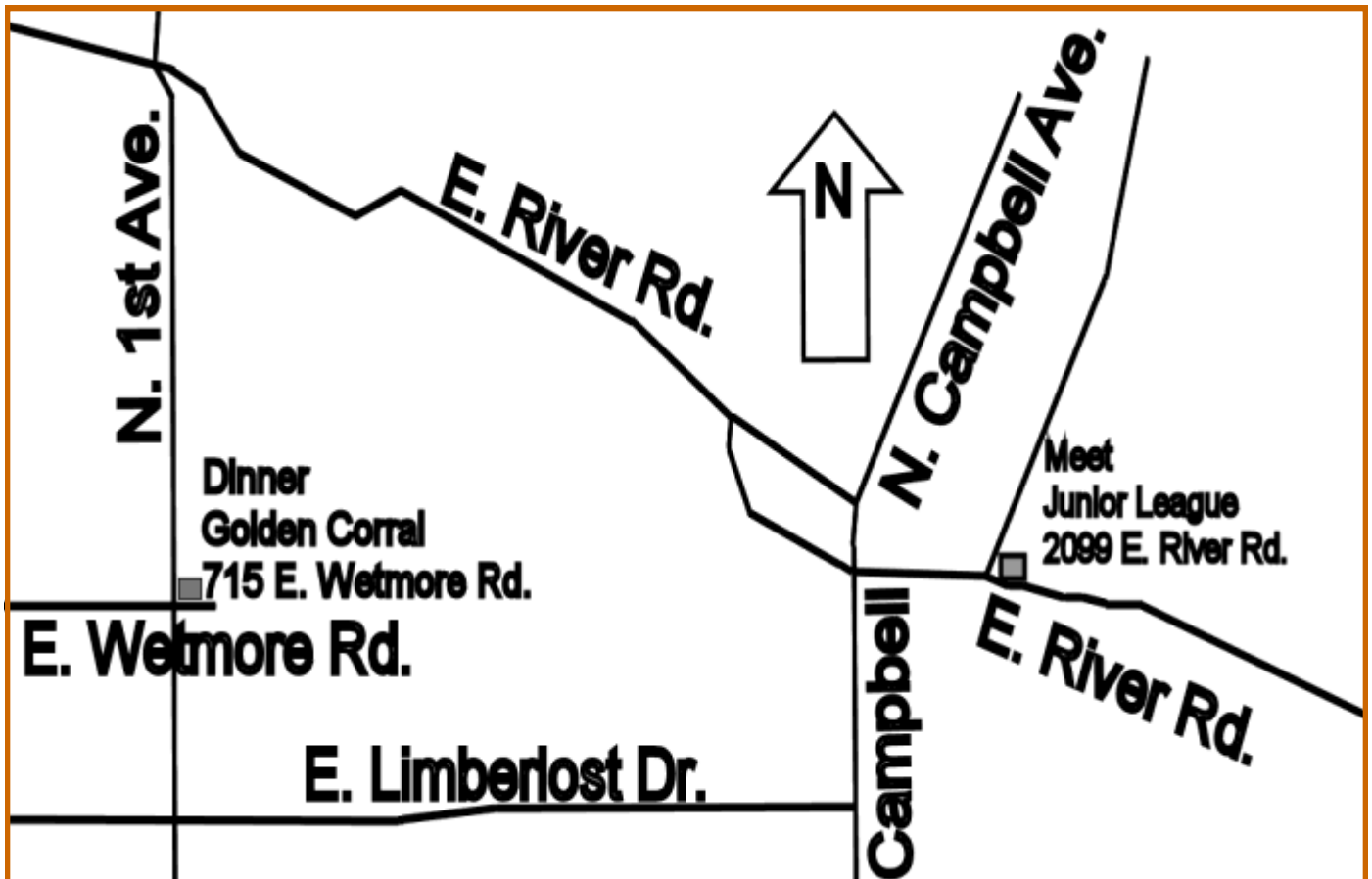

Join us in Tucson - Bring your models!